

Operating manual
Original operating manual
Item no.: 99988050
Rev.: 01 / 10/2019

Double diaphragm pump
PTI-MEM1060 with intelligent
magnetic field sensor
Year of manufacture: 2021



CE  II 2 G Ex h ib IIB T4 Gb X
II 2 D Ex h ib IIIC T135°C Db X

We reserve the right to make technical changes to the presentations and information in this manual that are necessary for improvement of the product characteristics.

All copyrights and protective rights to this product and all associated technical documentation shall remain with the company Timmer GmbH.

This manual is intended for every person who is assigned to perform tasks on and with the pump. It contains instructions and drawings that must not, either in whole or in part, be duplicated, disseminated, used for competitive purposes, or communicated to other persons without authorisation.

All rights reserved.

Copyright 2019 Timmer GmbH

Contents

1	EU Declaration of Conformity	6
2	About this manual	7
2.1	Use and safekeeping	7
2.2	Manufacturer information	8
2.3	Areas of applicability	8
2.4	Warranty.....	9
3	Safety	10
3.1	Basic information concerning safety	10
3.2	Compliance with the instructions in the operating manual.....	11
3.3	Operational prerequisites	12
3.4	Intended use	12
3.5	Non-intended use.....	13
3.6	Foreseeable misuse.....	14
3.7	Labelling on the pump.....	15
3.7.1	Rating plate	15
3.7.2	Labelling connection sensor	15
3.8	Qualifications of personnel.....	16
3.9	Personal protective equipment	16
3.10	Safety notices in the operating manual.....	16
3.11	Safety notices.....	18
4	Additional ATEX information	21
4.1	ATEX marking in accordance with Directive 2014/34/EU and DIN EN ISO 80079-36 for the pump	21
4.1.1	Ignition sources in the device.....	23
4.2	Explosion-proof sub-units.....	23
4.3	Note on the assembly according to Atex Directive 2014/34/EU	23
5	Transport	24
5.1	Check scope of delivery	24
6	Storage	24
7	Product description	25

8	Installation	26
8.1	Safety notices.....	26
8.2	Preparations.....	28
8.3	Connection.....	28
9	Commissioning	31
9.1	Safety notices.....	31
10	Operation	34
10.1	Regulating the delivery rate.....	34
11	Fault rectification	34
12	Cleaning	36
12.1	Safety notices.....	36
13	Maintenance	37
13.1	Safety notices.....	37
13.2	Maintenance schedule.....	39
13.3	Timmer Service.....	39
14	Decommissioning	40
14.1	Safety notices.....	40
15	Replacing components	41
15.1	Safety notices.....	41
15.2	Exploded-view drawing.....	43
15.3	Replacing the diaphragms.....	44
15.4	Replacing the pneumatic valve.....	45
15.4.1	Dismantling the pneumatic valve.....	46
15.4.2	Installation of the pneumatic valve.....	47
15.5	Replacing the ball valves and suction pipes.....	49
16	Disposal	51
16.1	Return shipment.....	51
17	Technical data	52
18	Spare parts for standard version	54
18.1	PTI-MEM1060.....	54
19	Appendix	54

19.1	Documentation of third-party manufacturers.....	54
------	---	----

1 EU Declaration of Conformity

DESIGN: DOUBLE DIAPHRAGM PUMP
Type: PTI-MEM1060 with intelligent magnetic sensor
ATEX marking: **CE**  II2 G Ex h ib IIB T4 Gb X
II2 D Ex h ib IIIC 135°C Db X

This double diaphragm pump has been designed and manufactured in accordance with the following EC/EU directives:

Directive 2006/42/EC OJEU L157/24 of 17 May 2006

Directive 2014/34/EU, OJEU L 96/309 of 26 February 2014

under the sole responsibility of (manufacturer):

Timmer GmbH

Dieselstrasse 37

48485 Neuenkirchen, Germany

www.timmer.de

The following harmonised standards have been applied:

EN ISO 12100:2010 Safety of machinery –

General principles of design – Risk assessment and risk reduction

EN 809:1998+A1:2009 Pumps and pump units for liquids – Common safety requirements

EN ISO 4414:2010 Pneumatic fluid power - General rules and safety requirements for systems and their components

DIN EN ISO 80079-36:2016: Explosive atmospheres - Part 36: Non-electrical equipment for explosive atmospheres– Basic method and requirements (ISO 80079-36:2016)

DIN EN ISO 80079-37:2016: Explosive atmospheres - Part 37: Non-electrical equipment for explosive atmospheres - Non-electrical type of protection constructional safety "c", control of ignition sources "b", liquid immersion "k" (ISO 80079-37:2016)

Person responsible for compiling the documentation: Timmer GmbH

Address: See manufacturer

Commissioning in potentially explosive atmospheres is prohibited until it has been established that the special conditions for intended use in potentially explosive atmospheres specified in the installation and operating instructions have been met. The conformity of the installed electrical device is confirmed by a separate declaration of conformity.

Neuenkirchen, 10.2019

City, date



Managing Director

2 About this manual

2.1 Use and safekeeping

Please note the following points:

- The pump can only be appropriately and safely commissioned, operated and maintained with the aid of this operating manual.
- This operating manual refers only to the product that is specified on the cover sheet.
- This operating manual is part of the scope of delivery.
- Consequently, always keep this operating manual in legible condition, within easy reach for the operator, in the vicinity of the pump. Keep this document with the pump in the event of resale or rental.
- This operating manual is intended only for instructed and authorised specialists.
- The Safety section provides an overview of all important safety aspects for optimal protection of personnel, and for safe and trouble-free operation of the pump.
- The manufacturer is not liable for damage resulting from failure to comply with the instructions in this operating manual.
- Reprints, translations and duplications in any form, including excerpts, require the written consent of the publisher.
- The copyright remains with the manufacturer.

2.2 Manufacturer information

Timmer GmbH

Dieselstrasse 37

48485 Neuenkirchen, Germany

Tel.: +49 5973 9493-0

Fax: +49 5973 9493-90

info@timmer.de

www.timmer.de

2.3 Areas of applicability

This product complies with the directives of the European Union.

In this regard, please note:

- The provided EU Declaration of Conformity
- The intended use
- Non-intended use

2.4 Warranty

For all Timmer pumps, we grant the initial purchaser a one year warranty on workmanship and material, starting from the date of purchase; provided that the pump is used as intended. Normal wear is excluded from the liability. The warranty is automatically null and void, if parts other than original Timmer spare parts are installed in the Timmer pump.

In accordance with applicable law, Timmer GmbH excludes all liability for consequential damages. In all cases the liability of Timmer GmbH shall be restricted to, and in no case shall exceed the equivalent value of the purchase price. Prior to purchase and shipment of the Timmer pump, the customer should review the national and local laws and regulations to ensure that the product, the installation and the application are in compliance with the applicable regulations.

- Notify the manufacturer immediately of warranty claims after defects or faults are detected.
- The information, illustrations and descriptions in this operating manual do not give rise to any claims for changes to systems and components that have already been delivered.
- No liability is accepted for damage or malfunctions that occur as described below:
 - Disregarding the operating manual
 - Unauthorised modifications of the system
 - Operating error
 - Failure to perform maintenance tasks

3 Safety

3.1 Basic information concerning safety

The Safety section provides an overview of all important safety aspects for optimal protection of personnel, as well as for safe and trouble-free use of the pump, from transport to operation and disposal.

Failure to comply with the instructions and safety notices cited in this operating manual can result in considerable hazards for personnel and material damage of the pump.

The pump is operationally reliable.

However more extensive residual hazards can be associated with operation of the pump under the following circumstances, if

- The pump is not used as intended.
- The pump is used improperly or operated by untrained or uninstructed personnel.
- The pump is not properly maintained or serviced.
- The safety instructions, notices and warnings specified in this operating manual are not complied with.
- The pump is improperly modified or converted.
- The prescribed maintenance is not performed in a timely manner.

3.2 Compliance with the instructions in the operating manual

Every person who is assigned to perform tasks on and with the pump must have read and understood this operating manual, particularly the "Safety" section.

Knowledge of and compliance with the content of this manual is the prerequisite for protecting personnel from danger and avoiding errors.

Therefore, all safety notices and safety instructions must be strictly complied with.

Compliance is for your own safety.

The operating manual is a component of the pump and must always be available in the vicinity of the product. The operating manual must be complied with. If the content of this operating manual leaves any questions unanswered or is not understandable, contact the manufacturer immediately – see the "Manufacturer information" section.

In addition to the safety instructions in this operating manual the following rules and regulations must also be complied with:

- Intended use
- The national and company-internal accident prevention regulations (UVV)
- Occupational health regulations
- Generally accepted rules for safety
- Country-specific regulations
- Manufacturer information (safety data sheets) for operating materials and auxiliary materials, chemical substances

Moreover, these rules and regulations can be supplemented with work instructions that take into account plant-internal regulations or operational particularities.

In supplementation to this operating manual, company-internal instruction with due consideration of the technical qualifications of the respective persons must also be provided.

At the same time, the instructions of the operating manuals of the installed electrical devices must be observed and complied with.

3.3 Operational prerequisites

Dependence on other installations and equipment must be tested by the owner separately.

Moreover, the following prerequisites must be met for regular operation of the pump, unless they are within our area of responsibility:

- Properly concluded installation
- Successful trial run with all required adjustment tasks
- Instruction of operating personnel concerning operation of the pump and the national safety regulations and the company's own safety regulations
- If hot or cold machine parts result in additional danger, then the customer must provide guards that prevent these parts from being touched
- The possibility of hazards due to electrical energy must be excluded (for details in this regard see VDE guidelines or guidelines issued by the electrical utility, for example)
- The pump must be easily accessible
- Determination of a person who is primarily responsible for proper operation

3.4 Intended use

- The pump and the operating manual are intended exclusively for commercial use.
- The pump must only be used for pumping fluid media (see section "Technical data").
- The pump must only be operated within the limits specified for intended use (see section "Technical data").
- The pumped medium must be compatible with the materials of the pump (see section "Technical data").
- The owner of the pump is responsible for selection of the medium to be pumped.
- The pump must only be operated in environments that do not adversely affect the properties of the materials used.
It is the responsibility of the owner to verify the suitability of the material.

3.5 Non-intended use

A use other than the use described in the section, "Intended use" and in this operating manual, and any use that extends beyond the specified intended use, is considered non-intended use. The manufacturer shall not be liable for damage resulting from non-intended use. This risk is borne solely by the user / owner. The following shall be considered as not intended use:

- Pumping of media that does not meet the product specification
- Do not modify the pump in any manner whatsoever.
- Use of the pump for purposes other than those cited in section 3.4
- Operating a damaged pump
- Operation, maintenance and repair of the system by unauthorised and/or untrained personnel
- Pump operation without earthing
- Pump operation outside of the specified parameters and/or operating data
- Operating the pump at a location where there are ignition hazards due to sources of ignition in the vicinity of the pump
- Use or commissioning of the pump by private users
- Modifying or converting the pump
- Set up on unsuitable substrates
- Attaching transport aids on the housing
- Failure to comply with the specified maintenance intervals
- Operating the pump in Zone 0 explosive gas/dust atmospheres
- Immersing the pump in the pumped medium
- Operation in explosive atmospheres without prior implementation of the requirements stipulated in Directive 1999/92/EC and national regulations for explosion protection, on the part of the owner
- Initial commissioning without prior inspection of the area and the pump by a person qualified to perform the inspection
- Pumping of media that is chemically incompatible with the materials used to construct the pump – The owner of the pump must check the chemical compatibility of the pumped media
- Pumping of media with parameters (e.g. ignition temperatures) that are not compatible with the information specified on the pump
- Operating the pump with bypassed safety devices is prohibited

3.6 Foreseeable misuse

The following points describe foreseeable misuse of the pump:

- Set up on unsuitable substrates
- Attachment of transport aids on the housing
- Failure to comply with the operating data
- Failure to follow the maintenance schedule
- Operation with unsuitable media
- Operation in the wrong Ex zone

3.7 Labelling on the pump

The data on the rating plate affixed on the pump must always be complied with. The rating plate must not be removed, and it must be kept in completely legible condition.

3.7.1 Rating plate

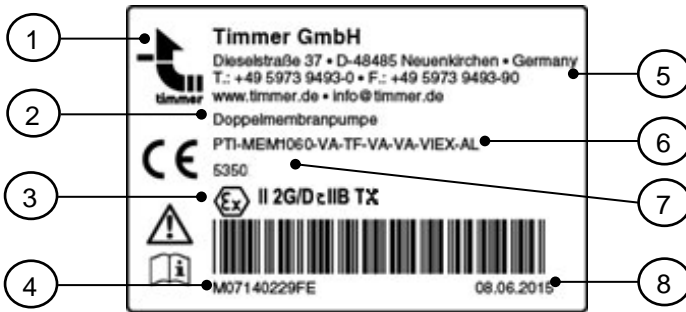
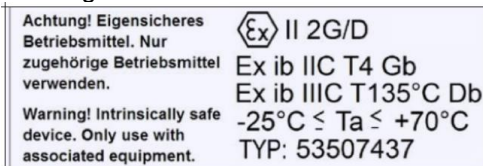

Fig. 1: Rating plate

- | | | | |
|---|--|---|----------------------|
| 1 | Logo | 5 | Manufacturer address |
| 2 | Product designation | 6 | Type key |
| 3 | ATEX marking in accordance with RL2014/34/EU | 7 | Item number |
| 4 | Serial number | 8 | Date |

3.7.2 Labelling connection sensor

Marking of the connection of the electrical sub-unit.



3.8 Qualifications of personnel

Tasks on the pump must only be performed in accordance with existing rules and statutory regulations, by personnel who have been instructed and who are qualified in this regard, in compliance with due diligence obligations.

The following requirements must be met:

- Personnel must have special skills and experience in the respective technical area. This particularly applies for maintenance and repair tasks on mechanical and pneumatic fixtures of the pump.
- Personnel must be familiar with applicable standards, directives, accident prevention regulations and operating conditions.
- Personnel must have been authorised by the person responsible for safety to perform each of the required activities.
- Personnel must be capable of recognising and avoiding possible dangers.

The required personnel qualifications are subject to different statutory regulations depending on the installation site. The owner must ensure compliance with applicable laws.

3.9 Personal protective equipment

Failure to wear the personal protective equipment can result in severe or fatal injury.

- Wear the operationally prescribed protective equipment, e.g. hearing protection, eye protection, safety footwear, hard hat, protective clothing and protective gloves for all tasks on the pump.



- Long hair must be tied back and covered; do not wear loose clothing or jewellery.
Danger of injury through snagging, being drawn in or entanglement due to moving parts.
- Ensure that there are no unauthorised persons in the danger zone.

3.10 Safety notices in the operating manual

WARNING

The signal word **WARNING** indicates a possible danger.

Failure to comply with the instruction can result in severe or fatal injury.

 **CAUTION**

The signal word **CAUTION** indicates a possible danger.
Failure to comply with the notice can result in minor to moderate injury.

! Attention

The signal word **Attention** indicates possible material damage.
Failure to comply with the notice can result in machine damage.

**Environmental protection notice**

The signal words **Environmental protection notice** indicate information on environmental protection.

 **Note**

The signal word **Note** indicates additional information for the machine or its use.

3.11 Safety notices

CAUTION

Hazard for personnel due to a defective pump!

- Check the pump regularly for damage and leaks.
- Switch off a damaged or leaking pump immediately.

CAUTION

Health impairment due to contact with harmful media!

- If the possibility of contact with the medium cannot be excluded, do not perform cleaning, repair, troubleshooting and fault rectification, until after you have put on the appropriate personal protective equipment PPE (at least protective clothing, protective gloves, protective goggles).
- Comply with the safety data sheets provided by the manufacturers and the national laws and regulations.

Caution

Pump damage due to the operating conditions and properties of the pumped media!

- The characteristics of the pumped media (such as abrasiveness, viscosity, etc.) and the operating conditions can have a negative effect on the service life and the function of the pump.
- Solids in the media can damage the pump, particularly the diaphragms, and cause immediate failure.

Caution

Pump damage due to media that is chemically incompatible!

- The owner of the pump must check whether the pumped media is chemically compatible with the materials that were used to construct the pump.

A list of the materials used in the pump is provided in the "Technical data" section.

Caution

Pump damage due to high mechanical forces!

- Do not subject the pump to strong mechanical forces.

Caution

Destruction of the pump due to excessive supply air pressure!

Excessive supply air pressure can destroy the diaphragms and cause the pump to burst.

- Operate the pump with a maximum supply air pressure of 8 bar.
- Ensure that the exit point of the pumped medium is not clogged or sealed.

WARNING

Danger of explosion due to improper installation tasks!

- During installation and dismantling, maintenance, transport to/from the place of use, and maintenance there is danger of generating sparks through friction, impact and rubbing processes or through electrostatic charging. Consequently, ensure that these hazards are safely eliminated or that an explosive atmosphere is not present during these work stages.

 **WARNING****When handling dangerous substances:**

The following instructions must be complied with if the hazard analysis conducted by the owner reveals that a possible leak of the medium poses an increased risk:

- The installation of media shut-off valves at the medium inlets and outlets to shut off the medium flow in case of a leakage on the pump.
- The installation of the pump with shut-off valve, 3-way valve and check valve in the compressed air supply line. These 3 components prevent the pumped medium from entering the compressed air system if a diaphragm tears.
- If diaphragms are completely defective, the fluid can enter the compressed air circuit, damage the compressed air circuit and exit via the silencer. Depending on the pumped medium, the silencer must be replaced by a suitable pipe or hose connection to avoid danger. The discharge must be taken to safe place.
- If diaphragms are completely defective, the medium to be pumped can react with materials in the compressed air circuit. Prior to commissioning the owner must assess the risk and take suitable measures.

**Environmental protection notice****Environmental pollution due to pumped media and cleaning agents.**

- Regularly check all lines, hoses and connections for leaks and apparent damage. Immediately repair any damage!
- Take up or wipe up leaked and spilled media and cleaning agents and dispose of them in an eco-friendly manner.
- Prevent escaped or spilled media and cleaning agents from getting into the groundwater.
- For safe and eco-friendly disposal of media, cleaning agents and replacement parts.
- Comply with the safety regulations applicable to the media and cleaning agents.

4 Additional ATEX information

4.1 ATEX marking in accordance with Directive 2014/34/EU and DIN EN ISO 80079-36 for the pump

CE  **2G Ex h ib IIB T4 Gb X / 2D Ex h ib IIIC 135°C Db X**

Symbol	Meaning
CE	CE mark.
	Marking relevant for explosion prevention in accordance with ATEX.
II	Atex device of Equipment Category II intended for use in explosive atmospheres, except for mines.
h	Non-electrical device for the explosive area.
ib	Labelling of intrinsically safe electrical equipment for use in potentially explosive atmospheres.
2 G/D	ATEX device of Equipment Category 2 (avoidance of effective ignition sources). The device can be used as intended in areas where Zone 1 and Zone 2 explosive gas or dust atmospheres can occur. Use of the device is prohibited in Zone 0.
IIB	The intended use is permitted in gas explosive areas with gases and vapours of explosion groups IIA and IIB. The intended use is not permitted in gas explosive areas with gases and vapours of explosion group IIC.
IIIC	Use as intended in potentially explosive dust atmospheres with dusts of dust groups IIIA, IIB and IIIC
T4	Temperature class for the gas explosion hazardous area.
T135°C	Surface temperature for the area with a dust explosion hazardous area.
Gb/Db	Device protection class for gas or dust. In normal operation and for the faults that can usually be expected (defects on the device), the device ensures the required degree of safety and avoidance of ignition sources.
X	The following special conditions must be met for safe operation of the pump in potentially explosive atmospheres. Observe restricted ambient temperature.

--	--

WARNING

Danger due to highly effective charge-generating processes!

- Highly efficient charge-generating processes can cause electrostatically dangerous charging of diaphragms that have a non-dissipative layer (e.g. PTFE) on the media side. Highly-effective processes that generate static charges, include flange purging of multiphase fluids and liquids with low conductivity ($< 100 \text{ pS/m}$) and the purging of the pump with compressed air.
The owner must take additional protective measures to safely prevent these processes. Possible measures include:
 - Filling the pipes and pump chambers with inert gas during dry-run
 - Slow filling and emptying of the pump
 - Reliable avoidance of dry-run (slurp operation)
- Highly-effective charge-generating processes can cause electrostatic charging of labels/stickers, silencers and ball valve handles. Highly efficient processes that generate charges include cleaning the pump with a high-pressure cleaner.
The owner must take additional protective measures to safely prevent these processes. Possible measures include:
 - Large-area, permanent covering of the labels/stickers with transparent conductive foil, or the removal of such labels/stickers (rating plates must not be removed).
 - Replacement of the silencer with a conductive/dissipative silencer.

WARNING

Danger of explosion due to hot surfaces!

The maximum surface temperature is equal to the max. temperature of the pumped medium and/or the compressed air temperature.

- In accordance with national regulations, the medium temperature/compressed air temperature must with certainty and with a sufficient differential, underlie the ignition temperature of the explosive atmosphere.

4.1.1 Ignition sources in the device

Mechanically generated sparks, chemical reaction and static electricity are potential ignition sources in the pump. The effectiveness of these ignition sources is reliably prevented, even in event of the usual errors, through integration into the equipotential bonding system and by limiting the operating parameter settings and ambient conditions.

The ignition hazards of the electrical device (intelligent stroke counter) are to be taken from its operating instructions. The electrical device may only be operated with the specified electrical parameters

4.2 Explosion-proof sub-units

No	Designation	Manufacturer	Type	Device identification
1	Magnetic nutrient sensor (intelligent stroke sensor)	Timmer GmbH	53507437	II 2G Ex ib IIC T4 Gb II 2D Ex ib IIIC T135°C Db -25°C ≤Ta≤+70°C

4.3 Note on the assembly according to Atex Directive 2014/34/EU

The pump PTI-MEM1060 Alu with intelligent stroke counter is to be understood as an assembly of mechanical parts (pump) and an electrical device (intelligent stroke counter) according to ATEX directive 2014/34/EU. These sub-assemblies of the assembly are ATEX/CE-compliant sub-assemblies. The assembly has been subjected to a risk assessment for additional ignition hazards and other relevant hazards that could become relevant as a result of the combination. It was found that the assembly did not change the explosion characteristics of the sub-assemblies with regard to the essential health and safety requirements and did not give rise to any additional ignition hazards. An assessment of the assembly as electrical equipment by a Notified Body is therefore not necessary (ATEX Guidelines to Directive 2014/34/EU, 1st edition of April 2016, §43 electrical equipment and §44 Combined components (assemblies) 2.b)). In this case, it is sufficient if the manufacturer

- prepared the technical documentation,
- affixes the CE marking and the Ex marking in accordance with Annex II point 1.0.5 of the Atex Directive 2014/34/EU to the assembly - indicating the intended use,
- signed the EU declaration of conformity for the entire assembly,

- indicates the technical specifications/standards applied, and
- Provides operating instructions
- if applicable, the technical documents are deposited with a notified body.

5 Transport

To prevent transport damage, if possible only transport the pump only in its original packaging.

5.1 Check scope of delivery

1. Remove the transport packaging of the pump.
2. Dispose of the packaging material properly.
2. Examine the pump for transport damage.
 - Immediately notify the transport company and the manufacturer of transport damage, in writing.
 - Protect the pump from further damage.
3. Use the delivery note to verify the completeness of the delivery.

6 Storage

- The storage conditions influence the service life of the diaphragms.
- The pump must not be stored for safekeeping unless it has been thoroughly cleaned beforehand.
- Extreme storage conditions accelerate the ageing process.
- We recommend a storage temperature between +10 °C and +25 °C.
- The diaphragms must not be exposed to heat sources or direct sunlight.
- Exclude the possibility of exposure to ozone or ionising radiation.
- Store the diaphragms in tension-free condition.
- We recommend replacing the diaphragms at the latest after one year of storage under the storage conditions cited above.

7 Product description

The double diaphragm pump is a self-priming, pneumatically driven fluid pump. The fluid is conveyed by the opposing movement of two diaphragms. A reversing valve ensures that the two diaphragms are alternately charged with compressed air. Each diaphragm has a fluid inlet valve and a fluid outlet valve. If the pump chamber is enlarged due to movement of the diaphragm, the outlet valve closes and the inlet valve opens so that fluid is suctioned into the pump chamber. When the diaphragm moves in the other direction, the pump chamber becomes smaller, the inlet valve closes, the outlet valve opens and the fluid is pumped out.

When one of the diaphragms reaches its end position in the suction process, the limit switch activates the reversing valve so that the other diaphragm is charged with compressed air.

The reversing valve is designed in such a manner that it cannot remain in a middle position.

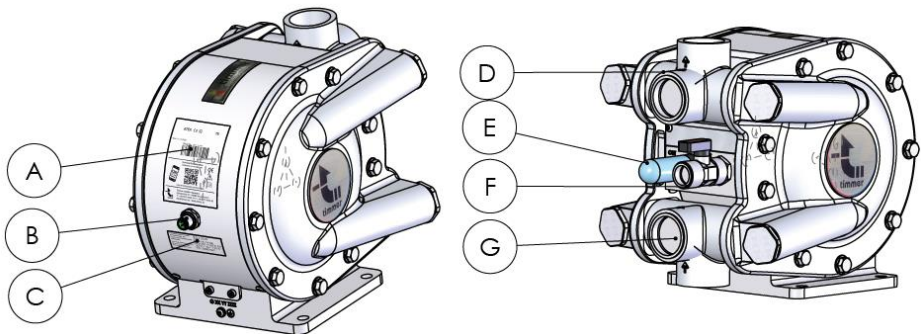

Position	Designation
A	Type plate
B	Connection stroke counter
C	Label stroke counter ATEX info
D	Media outlet
E	Silencer
F	Compressed air connection
G	Media inlet

8 Installation

8.1 Safety notices

WARNING

Personnel are in danger due to improper installation!

- Connections must be used that are made of material that is compatible with the pumped medium and with the material of the pump.
- The pump does not have its own pneumatic shut-off valve. If the pump cannot be switched off by simply, safely disconnecting or switching off the compressed air supply, an additional, easily accessible shut-off valve must be installed upstream of the compressed air connection.
- The pump must be integrated in the compressed air system in such a manner that it can be taken out of service by switching off the compressed air.
- Select the installation location for the pump in such a manner that the possibility of impacts that can cause ignition is excluded.
- The compressed air supply (hoses, etc.) must be installed in such a manner that they do not pose any hazard.
- Use a pressure relief valve in the compressed air supply if there is a risk of exceeding the operating parameters.

WARNING

Danger of explosion due to electrostatic charging!

- Before commissioning, connect the pump to the protective earth system (equipopotential bonding).

WARNING

Personnel are in danger due to improper installation!

- Installation tasks must only be executed by trained personnel.
- Wear personal protective equipment (PPE).

 **CAUTION****Personnel are in danger due to inadequate lighting!**

- Only perform installation tasks on the pump in an adequately illuminated and air-conditioned environment.

! Attention**Fault or damage due to residual substances in the pump**

- Prior to commissioning, purge the pump with suitable media to remove from the pump interior any substances introduced during the customer process (goods receipt, handling, storage, installation, etc.) that are detrimental to paint adhesion, or substances that are incompatible with the pumped medium.
- For this, strictly comply with the instructions in section 12 Cleaning

8.2 Preparations

- Do not use the pump as a support for the piping system.
- Ensure that the system components are properly supported to prevent weight load on the pump parts.
- Ensure that the regulations regarding the protective earth system (equipotential bonding) are complied with.

► Note

- An electrical connection is not required.
- The pump is self-priming.

8.3 Connection

1. Ensure that the pump is in a stable position through fixation using suitable fastening screws.

Do not immerse the pump in the pumped medium.

Check whether additional shut-off valves must still be installed.

Pump with springs in the media valves

A deviating positioning of the pump is possible, however in this case you will have to vent the pump chambers during the commissioning process.

Start-up of the pump in the preferred horizontal position with maximum frequency.

2. Install a compressed air hose from the compressed air source to the pump.

The pump has an 8 mm diameter plug connection (1) or a connection in accordance with the technical data.

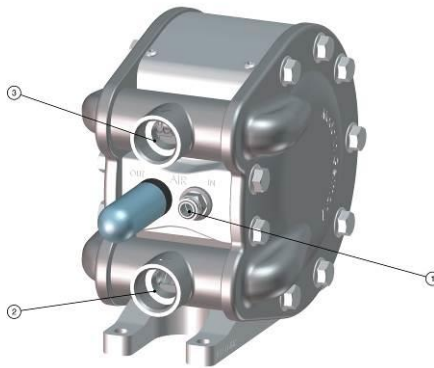

Fig. 2: Connections on the pump

3. Use flexible connections (for example hose connections) for intake and delivery.
The flexible connections prevent transmission of vibration to the piping system.
4. Ensure that the connectors are compatible with the pumped medium and withstand the high pressures.
5. Dimension the conductor cross-sections sufficiently large.
The sizes depend on the viscosity of the medium and the conditions of the system.
6. Always use suitable hose clamps to connect the intake hose and delivery hose.
The direction of flow is indicated by arrows on the pump housing. Pay strict attention to these arrows; do not remove them, keep them in faultless, recognisable condition.
7. Connect the intake hose to the entry point (2).
8. Connect the delivery hose to the exit point (3).
9. Connect the pump to a protective earth system.

The connection for the equipotential bonding is appropriately marked on the pump base (1).

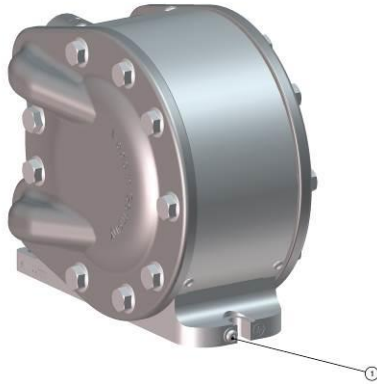

Fig. 3: Connection for the equipotential bonding

10. Check all connection points firm seat and leak-tightness.
11. Connect the compressed air hose to the compressed air supply of the pump.

9 Commissioning

9.1 Safety notices

WARNING

Danger of explosion due to dust on the pump housing!

- Regularly clean the surface of the pump housing and remove the layers of dust.

WARNING

Life-threatening danger due to pumping explosive media in hazardous areas!

The medium to be pumped can corrode or otherwise damage components of the pump and escape. This can result in an explosive mixture.

- Pumping of explosive media or gases is prohibited
- The intended use in the Ex environment is only possible in due compliance with Directive 2014/34/EU, in accordance with the marking on the rating plate of the pump:

CE  II 2 G Ex h ib IIB T4 Gb X

II 2 D Ex h ib IIIC T135°C Db X

 **WARNING****Life-threatening danger when operating the pump in hazardous areas!**

- The pump may be used in explosive areas (for example paint shops), only if this is appropriately indicated on the pump rating plate.
- Moreover the owner of the pump is obligated to comply with the requirements stipulated in Directive 1999/92/EC.
- The pump may only be used in explosive atmospheres (e.g. paint shops) if the ATEX markings on the rating plate of the pump and its sub-devices meet the requirements of the zone classification.
- During operation, ensure that the pump is always completely filled with fluid. The continuous pumping of ignitable gas/fluid mixtures that cause a Zone 0 to occur inside the pump, is prohibited.
- The pumped medium can react exothermally with the material of the pump. Before pumping the medium, check the suitability of the pump materials for the medium to be pumped.
- Operation of the pump above the permissible flow rate and longer dry-run operation can cause overheating of the pump.
- When pumping media in ring systems, the delivery capacity of the pump is converted into heat. For short lines, this can cause dangerous heating of the medium.
- Operation of the pump can adiabatically compress explosive gas mixtures in the pump and/or the piping system. This can result in increases in temperature that pose an ignition hazard. The owner must take appropriate measures. The media outlet must not be closed during pump operation.
- The special operating conditions of the pump must be noted and complied with.

Caution

Destruction of the pump due to excessive supply air pressure!

Excessive supply air pressure can destroy the diaphragms and cause the pump to burst.

- Operate the pump with a maximum supply air pressure of 8 bar.
- Ensure that the exit point of the pumped media is not clogged or closed
- Ensure that the exit point of the pumped medium is not clogged or sealed.

1. If the pump has not been mounted on a horizontal, level surface with the pump base downwards, vent the pump chambers.
2. Set the compressed air pressure between 1 and 8 bar.
The pump is ready for operation.
3. The pump starts pumping as soon as it is charged with compressed air.
4. Operate the pump with supply air pressure of maximum 8 bar.

10 Operation

10.1 Regulating the delivery rate

► Note

If the delivery rate of the pump must be regulated, the owner must install a throttle valve in the compressed air supply or in the delivery line.

Reduce the delivery rate

- Reduce the compressed air supply or the medium outflow.

Increase the delivery rate

- Increase the compressed air supply or the medium outflow.

11 Fault rectification

Fault	Fault cause	How to eliminate the fault
Pump does not run or it runs too slow	Insufficient compressed air pressure	Set pressure between 4 and 8 bar
	The hose cross-section is too small	Use a hose with a larger cross-section
	Control valve leaks	Replace distributor valve and seals
	Clogging of the silencer, pump does not run smoothly, seal is swollen or piston material is damaged	Check material resistance, avoid dry run
Pump runs but does not pump any medium, or does not stop when the pressure side is shut off	Valves contaminated	Flush the pump with cleaning agent
	Delivery hose is clogged	Clean delivery hose
	Suction and pressure valves are contaminated	Let the pump run for 10 to 20 minutes at top speed

Fault	Fault cause	How to eliminate the fault
	Connections leak, possible intake of external air, vacuum collapses	Check connections for leaks; re-seal
	Valves contaminated	Clean or replace the valves
	No suction effect on the suction-side and pressure-side	Close openings with your hands to check the suction effect and, if necessary, replace the seals
	Excessive viscosity of the pumped medium	High-viscosity media cannot be pumped (see section "Technical data" for the limit values)
	Delivery hose has cracks or holes	Replace delivery hose
	Excessive counterpressure at the injection point	Reduce counterpressure at the injection point
	Threaded fittings, ball valve or non-return valve either have no passage or reduced passage	Restore passage: Clean or replace the components
	Air in the pump chamber	Vent the pump
Fluid container runs empty autonomously	Exit point of the fluid is lower than the fluid level in the container	Place the fluid container lower or position the exit point higher

12 Cleaning**12.1 Safety notices****Caution****Pump damage due to hardening, crystallising media!**

- When pumping fluids containing solids that harden, crystallise, or that can corrode pump materials due to chemical or physical properties, the pump must be cleaned before longer standstill periods!
 - A longer standstill period is defined depending on the previously pumped medium and the change of its aggregate state from fluid to solid.
 - The definition is the responsibility of the owner and must be complied with in any case to avoid pump damage.
-

1. Only clean the pump with a cleaning agent that is suitable for the pump material and the pumped medium.
Water or solvents could be suitable.
Liquid and solid cleaning agents must not exceed a temperature of 65 °C.
2. Connect the suction pipe connection to the cleaning agent tank.
3. Connect the media outlet to a suitable container.
4. Pump the cleaning agent until all residues in the pump are detached.
5. Completely empty the pump.
6. To do this, pull the suction hose out of the cleaning agent far enough that air is suctioned in.
7. When cleaning agent no longer drains from the outlet, completely disconnect the media inlet and outlet of the pump.
8. To completely empty the pump, swivel it 90° so that the media connections point downward.

 **Note**

In the event of decommissioning and storage, complete emptying of the pump is necessary, because under certain circumstances the cleaning fluid can accelerate the ageing of the pump diaphragms.

9. Operate the pump with supply air pressure of approx. 1 bar.
10. In this process move the pump slightly back and forth until the residual quantity has completely run out.
11. Clean the outer parts of the pump.

Cleaning before decommissioning

1. Clean and empty the pump as described in the preceding paragraph.
2. Because it is subject to normal ageing, replace the pump diaphragm after one year of storage, at the latest, to ensure safe and reliable function of the pump.

Extreme storage conditions can accelerate the ageing process.

13 Maintenance**13.1 Safety notices** **WARNING****Hazard for personnel due to trapped compressed air and pressurised medium!**

- Do not service or clean the pump, hoses and the outlet valve for the compressed air while the system is pressurised.
- Before performing tasks on the pump de-pressurise the pneumatic section and the fluid section.
- Shut off the compressed air supply and wait until the residual pressure is dissipated via the outlet valve for the compressed air.
- Empty the pump before replacing components.

 **WARNING**

Hazard for personnel due to spraying fluids (media)!

- Ensure that the material hoses and other components can withstand the fluid pressure generated by this pump.
- Regularly check the pump for damage or wear.
- Ensure that the pneumatic valve, the outlet area for the compressed air and the suction side and pressure side for the medium are clean and function effectively.
- Depressurise the pump before dismantling. Under some circumstances there can still be a low residual pressure in the pressure chamber that causes medium to spray out.
- Before any dismantling tasks on the pump, comply with the safety data sheets provided for the previously pumped chemicals.

 **WARNING**

Personnel are in danger due to improper installation!

- Installation tasks must only be executed by trained personnel.
- Wear personal protective equipment (PPE).

 **CAUTION**

Personnel are in danger due to inadequate lighting!

- Only perform installation tasks on the pump in an adequately illuminated and air-conditioned environment.

The double diaphragm pump is low-wear except for the diaphragms. The quality of the compressed air supply, the characteristics of the pumped media (such as abrasiveness, viscosity, etc.) and the operating conditions can negatively influence the service life of the pump.

Consequently we recommend regular inspection of the pump and of the pneumatic valve.

Nevertheless, should a fault occur, or if the delivery capacity decreases, you can perform the following tasks:

- Replace the diaphragms
- Clean the fluid valves
- Replace the seals
- Clean and grease the pneumatic valve

13.2 Maintenance schedule

Draw up a maintenance schedule based on the service life of the pump.

Such a maintenance plan with maintenance intervals is particularly important to maintain the proper function of the pump.

13.3 Timmer Service

We recommend that you have Timmer Service perform all recurring maintenance tasks, particularly for the entire pneumatic unit.

Timmer offers a comprehensive service concept in this regard.

14 Decommissioning

14.1 Safety notices

WARNING

Personnel are in danger due to improper installation!

- Installation tasks must only be executed by trained personnel.
 - Wear personal protective equipment (PPE).
-

CAUTION

Health impairment due to contact with harmful media!

- If the possibility of contact with the medium cannot be excluded, do not perform cleaning, repair, troubleshooting and fault rectification, until after you have put on the appropriate personal protective equipment PPE (at least protective clothing, protective gloves, protective goggles).
 - Comply with the safety data sheets provided by the manufacturers and the national laws and regulations.
-

Shut off the compressed air supply to the pump, if the system will not be used for a longer period of time.

15 Replacing components

15.1 Safety notices

WARNING

Personnel are in danger due to improper installation!

- Installation tasks must only be executed by trained personnel.
- Wear personal protective equipment (PPE).

WARNING

Hazard for personnel due to spraying fluids (media)!

- Ensure that the material hoses and other components can withstand the fluid pressure generated by this pump.
- Check the pump for damage or wear on a regular basis.
- Ensure that the pneumatic valve, the outlet area for the compressed air and the suction side and pressure side for the medium are clean and function effectively.
- Depressurise the pump before dismantling. Under some circumstances there can still be a low residual pressure in the pressure chamber that causes medium to spray out.
- Before any dismantling tasks on the pump, comply with the safety data sheets provided for the previously pumped chemicals.

WARNING

Hazard for personnel due to trapped compressed air and pressurised medium!

- Do not service or clean the pump, hoses or the outlet valve for the compressed air while the system is pressurised.
- Before performing tasks on the pump de-pressurise the pneumatic section and the fluid section.
- Shut off the compressed air supply and wait until the residual pressure is dissipated via the outlet valve for the compressed air.
- Empty the pump before replacing components.

 **CAUTION****Personnel are in danger due to inadequate lighting!**

- Only perform installation tasks on the pump in an adequately illuminated and air-conditioned environment.

Caution**Pump damage due to incorrect tightening torque of the housing screws!**

- The prescribed tightening torque for the hexagon screws of the housing cover is 25 Nm.
- To prevent pump damage and leaks, do not exceed this value.
- Use a calibrated torque spanner.

15.2 Exploded-view drawing

Fig. 4: Exploded-view drawing (Sensor not shown)

15.3 Replacing the diaphragms

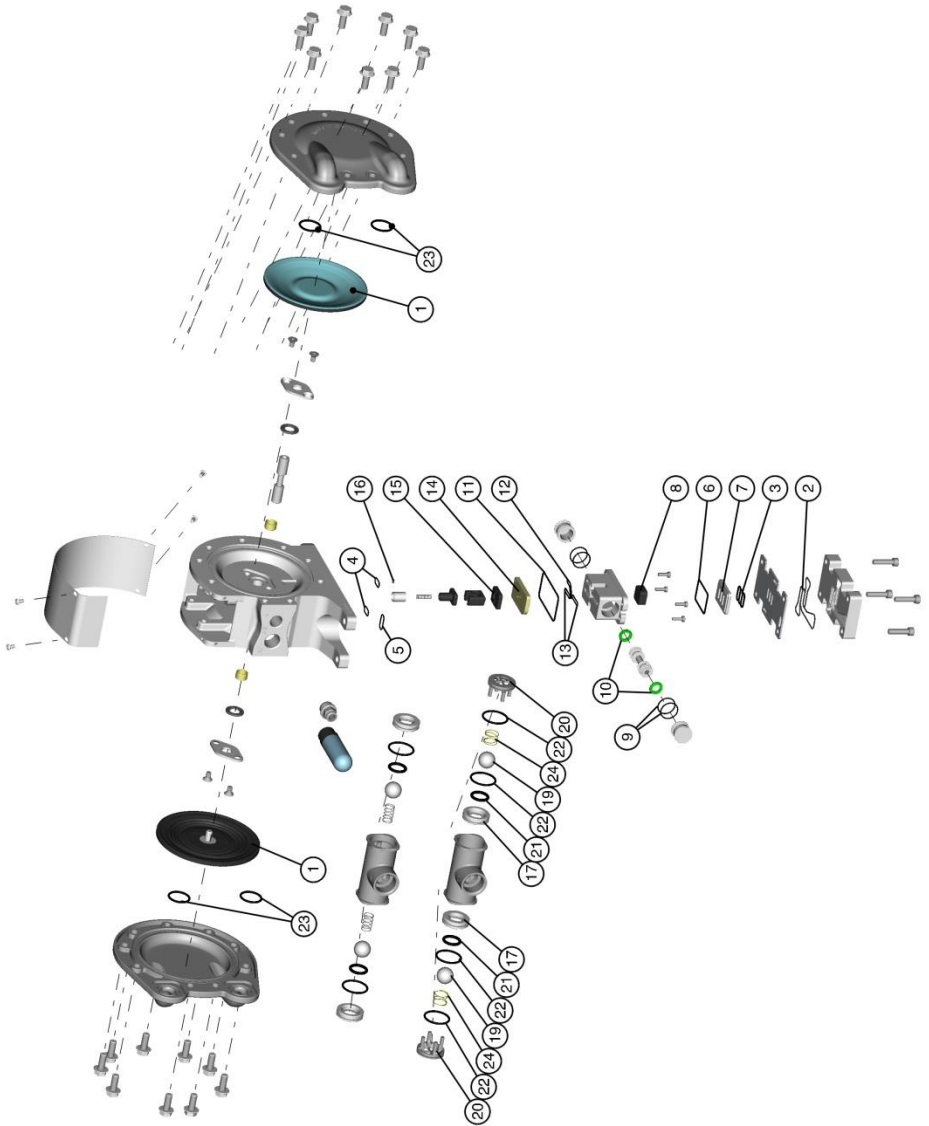
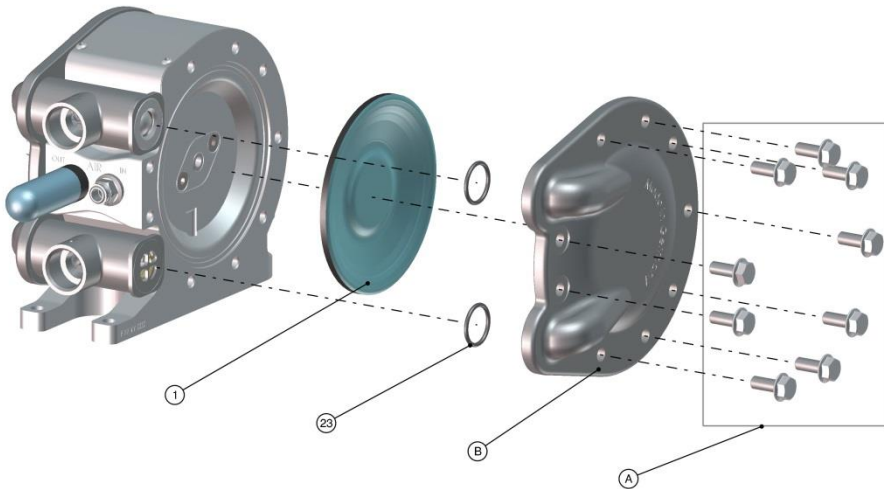

Fig. 5: Replacing the diaphragms

1. Unscrew the hexagon screws (A) on one of the housing covers (B) and remove the housing cover (B).
2. Remove the diaphragm (1) from the piston rod by turning it counterclockwise.
3. Fasten the diaphragm (1) clockwise on the piston rod.
4. Mount the housing cover (B) with the hexagon screws (A).
Ensure that the O-rings are seated in the grooves in the cover.
5. Tighten the hexagon screws crosswise with tightening torque of 25 Nm.
6. Repeat the procedure on the other side of the diaphragm.

15.4 Replacing the pneumatic valve

Fig. 6: Replacing the pneumatic valve

1. Unscrew the hexagon screws (A) on the base plate (B) and remove the base plate (B).
2. One after the other, remove the seal (2), the intermediate plate (C), the O-rings (4) and (5), the seal (3), the ceramic plate (7), the O-ring (6) and the main valve gate (8).
3. Unscrew the hexagon screws (D) and remove the pneumatic valve (S) from the pump housing.

15.4.1 Dismantling the pneumatic valve

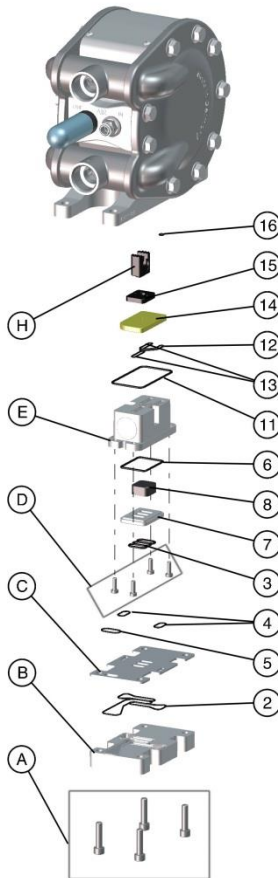
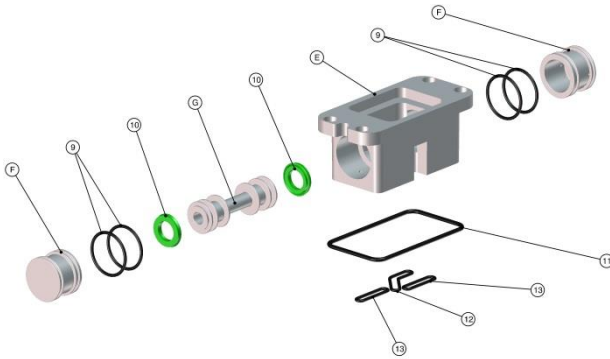

Fig. 7: Dismantling the pneumatic valve

1. Remove the O-rings (11), (12) and (13) from the grooves of the pneumatic valve block (E).
2. Remove the caps (F) and the installed O-rings (9).
3. Remove the gate valve (G) and the piston seals (10) from the pneumatic valve block (E).
4. Clean the parts with a suitable cleaning agent!
Check media compatibility beforehand!
5. Check the parts, particularly the O-rings, and replace defective parts.

15.4.2 Installation of the pneumatic valve

1. Place the O-rings (16) in the grooves in the middle section of the pump. The O-rings keep their position better if they are greased.
2. Place the control valve gate (15) with the chamfered side in front, in the middle section of the double diaphragm pump. The groove of the gate valve must engage with the groove of the follower (H) (Fig. 6).

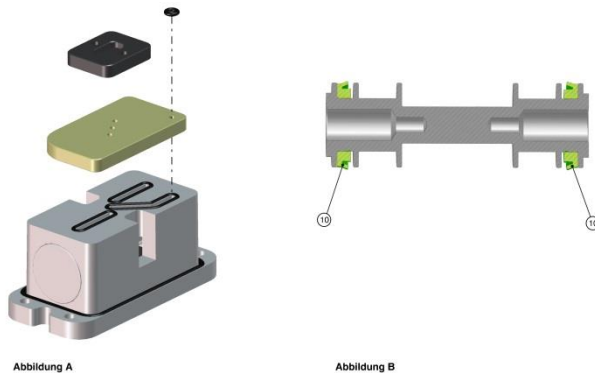

Fig. 8: Position of the ceramic plate

3. Insert the ceramic plate (14) in the middle section of the pump so that the holes align with the O-ring (16) (see Figure A).
 4. Mount the pneumatic valve block (E) in the reverse sequence.
 5. Before mounting, lubricate the seals and O-rings (e.g. with Fuchs® Renolit Unitemp 2) and avoid any damage to the seals and O-rings when mounting.
Particularly grease the raceways of piston seals (10) in the caps (F)
 6. Mount the piston seals (10) as shown in Figure B on the gate valve (G).
 7. Insert the slider (G) into the pneumatic valve block (E).
 8. Insert the O-ring (11) in the outer groove of the pneumatic valve block (E).
 9. Place the O-rings (12) and (13) in the groove of the pneumatic valve block (E).
- When mounting, ensure that the O-rings remain in the grooves and that they are not damaged.

Replacing components

10. Insert the mounted pneumatic valve block (E) (see Fig. 6) in the middle section of the pump. The install direction is shown in Fig. A (see Fig. 8).
11. Insert the main valve gate valve (8) with the closed side in front in the pneumatic valve block (E). The main valve gate (8) must be inserted so that the piston rod can move the gate valve (G).
12. Insert the O-ring (6) in the pneumatic valve block (E).
Ensure that the installation is correct (the side without O-ring groove first).
13. Place the O-rings (3), (4) and (5) in the central part of the double diaphragm pump, the grooves provided for this purpose.
Ensure that the O-rings are not damaged or detached.
14. Insert the ceramic plate (17) in the pneumatic valve block (F).
Ensure that the installation is correct (side with the large O-ring (9) first).
15. Place the O-rings (5) and (6) in the middle part of the pump in the grooves provided for this purpose.
Ensure that the O-rings are not damaged or detached.
16. Place the intermediate plate (C) in the middle section of the pump.
17. Place the plate (B) with the seal (2) in the middle section of the pump.
18. Fasten the plate (B) with the cylinder screws (A).
The fillister head screws must be fastened uniformly with a torque of 10 Nm.

15.5 Replacing the ball valves and suction pipes

► Note

The version of the media valves of pump PTI-MEM1060 is specified at the end of the operating manual.

The pumps can be clearly identified by the item number on the rating plate!

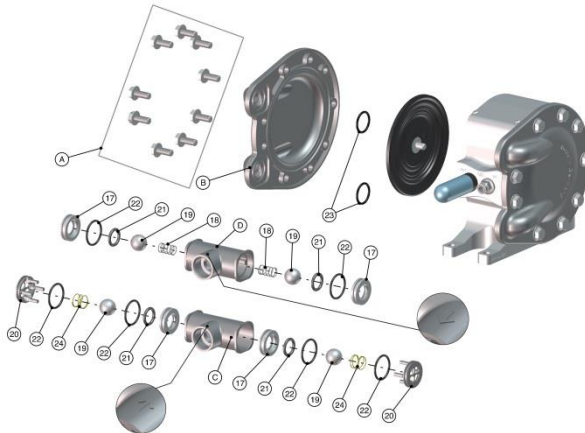

Fig. 9: Replacing the ball valves and suction pipes

1. Unscrew the hexagon screws (A) on one of the housing covers (B) and remove the housing cover (B).
2. Remove the suction pipe (C) and the pressure pipe (D) with the O-rings (23) from the pump.
3. Remove the suction pipe (C) and the pressure pipe (D) in accordance with the drawing.
4. Clean the parts with a suitable cleaning agent.
Check media compatibility beforehand!
5. Check the parts, particularly the O-rings, for damage and wear.
Replace defective components.
6. Mount the valve seats with valve balls and O-rings in the reverse sequence.

► Note

Replacing components

Do not swap out the upper and lower valve!

Pay attention to the installation direction of the ball seats (17) accordance with the drawing! The large inner chamfer of the ball seat (17) must point to the ball!

7. Mount the O-rings (23) into the grooves of the pump cover (B).
8. Mount the suction pipe (C) and the outlet pipe (D).
In this regard, pay attention to the marking of the flow direction.
9. Mount the housing cover (B) with the hexagon screws (A). The hexagon screws must be uniformly tightened with torque of 25 Nm.

Alternative suction pipe and pressure pipe position

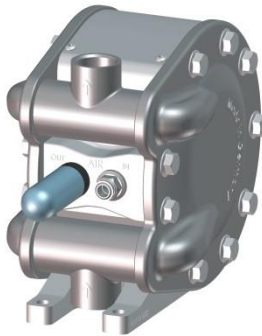

The suction pipe or pressure pipe position can also be varied by rotating the pipes at installation. The possible position is shown on the drawing. Pay attention to the position of the suction pipe and the pressure pipe. The arrows indicate the flow direction!

16 Disposal

16.1 Return shipment

Please send the pump to the following address:

Timmer GmbH

Dieselstrasse 37

48485 Neuenkirchen, Germany

Germany

Note

- Please send the pump in the original packaging, to avoid transport damage.
- The pump must be flushed and the surface must be clean.
- If flushing is not possible, the media connections must always be sealed leak-tight to prevent the medium from running out.
- Always include a safety data sheet of the last pumped medium or cleaning agent with the returned pump.

17 Technical data

General data	
Operating conditions	+5 ... +40 °C at maximum 80% relative humidity
Maximum delivery rate	approx. 60 l/min (at 6 bar, free outlet, water)
Drive	Pneumatic
Compression ratio	1 : 1
Fluid connections	3/4" BSP thread
Operating pressure	Maximum 8 bar compressed air, filtered in accordance with DIN ISO 8573
Compressed air connection	Plug connection diameter 8 mm
Air connection	Minimum diameter: 6 mm, interior
Suction head, dry	Maximum 3.5 m
Weight	< 6.2 kg
Maximum viscosity of the medium	approx. 15.000 mPa•s
Temperature of the pumped medium	+5 ... +65 °C
Sound pressure level	< 68 dB(A)

Materials of the parts that come into contact with the medium	
Housing	Stainless steel
Suction pipe / pressure pipe	Stainless steel
Diaphragms	PTFE*
Ball valves / springs	Stainless steel*
Fluid seal	FEPM*
Valve seats	Stainless steel

*Additional materials, such as EPDM, PEEK, FFKM and NBR are available!

18 Spare parts for standard version

18.1 PTI-MEM1060

Item	Item number	Quantity	Description	
001	53501026	2	Diaphragm	Wear parts package – diaphragm item no. 53507060
017	53507021	4	Cage lower part	Wear parts package media valves item no. 53507168 (Incl. media seals item no. 53507063)
018	79010624	2	Spring	
019	70050015	4	Ball diameter 20	
020	53507013	2	Cage (ball diameter 20)	
024	79010650	2	Spring	
021	70010529	4	O-ring 16x3.5	Wear parts package media seals item no. 53507063
022	70010530	6	O-ring diameter 27x2.5	
023	70010687	4	O-ring diameter 22.22x2.62	

► Note

Spare parts are only available through the wear parts packages. The packages differ depending on the selected variant. In this case the spare parts numbers are provided separately.

Use only original Timmer spare parts.

19 Appendix

19.1 Documentation of third-party manufacturers

Manufacturer	Designation
Timmer GmbH	Operating Instructions Intelligent field sensor

Index**A**

About this manual 7
Areas of applicability 8

B

Basic information concerning safety 10

C

Check scope of delivery 24
Cleaning 36
Commissioning 31
Compliance with the instructions in the operating manual 11
Connection 28

D

Decommissioning 40
Dismantling the pneumatic valve 46
Disposal 51

E

EU Declaration of Conformity 6
Exploded-view drawing 43

F

Fault rectification 34
Foreseeable misuse 14

G

Guarantee and warranty 9

I

Installation 26

Installation of the pneumatic valve 47

Intended use 12

L

Labelling on the pump 15

M

Maintenance 37
Maintenance schedule 39
Manufacturer information 8

N

Non-intended use 13

O

Operation 34
Operational prerequisites 12

P

Personal protective equipment 16
Preparations 28
Product description 25

Q

Qualifications of personnel 16

R

Rating plate 15
Regulating the delivery rate 34
Replacing components 41
Replacing the ball valves and suction pipes 49
Replacing the diaphragm 44
Replacing the pneumatic valve 45

S

Safety 10
Safety notices 18, 26, 31, 36, 37,
40, 41
Safety notices in the operating
manual 16
Spare parts 54
Storage 24

T

Technical data 52
Timmer Service 39
Transport 24

U

Use and safekeeping 7



Timmer GmbH
Dieselstrasse 37
48485 Neuenkirchen, Germany
Germany

Tel.: +49 5973 9493-0
Fax: +49 5973 9493-90
info@timmer.de

www.timmer.de